

4

3

2

1

© COPYRIGHT 2007 BY TYCO ELECTRONICS CORPORATION ALL RIGHTS RESERVED. TOUS DROITS RESERVES

LOC DIST
FH 00

REVISIONS					
P	LTR REV	DESCRIPTION MODIFICATIONS	DATE	DWN DESS	APVD APPR
	C	EQ00-0326-08	22-Aug-08	EN	LR

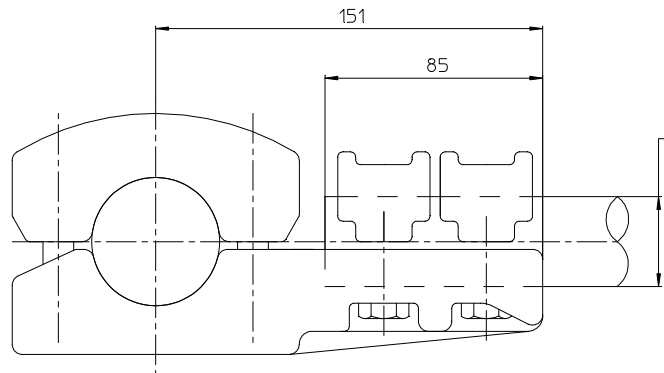

Cable ou tube ø31 à 35.99
 Cable or tube 31DIA to 35.99
 Cable o tubo ø31 a 35.99

Tube ou borne ø46 à 50.99
 Tube or terminal 46DIA to 50.99
 Tubo o borna ø46 a 50.99

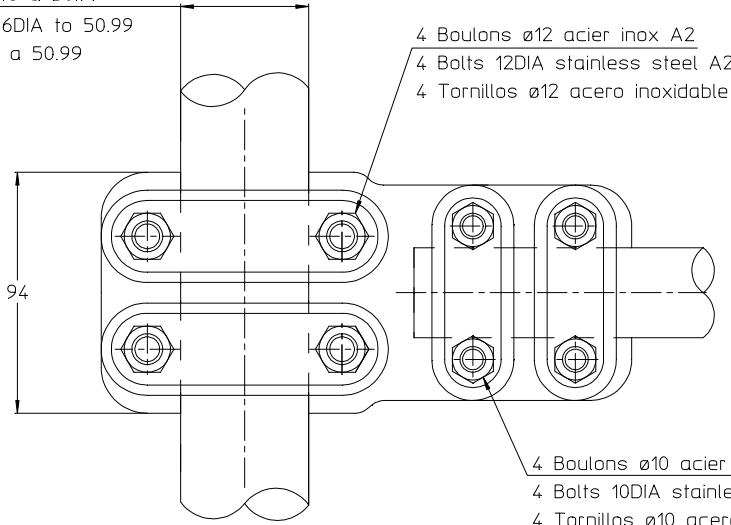

60 Nm

4 Boulons ø10 acier inox A2
 4 Bolts 10DIA stainless steel A2
 4 Tornillos ø10 acero inoxidable A2

37 Nm

<small>THIS DRAWING IS CONTROLLED BY TYCO ELECTRONICS CORPORATION. IT IS SUBJECT TO THE REVISIONS AND THE ENGINEERING ORGANIZATION OF TYCO ELECTRONICS. SIMEL SHOULD BE CONTACTED FOR THE LATEST REVISION. CE PLAN EST UN DOCUMENT CONTRÔLÉ PAR TYCO ELECTRONICS CORPORATION. IL EST SUSCEPTIBLE D'ÊTRE REVISÉ. POUR OBTENIR LA DERNIÈRE RÉVISION, CONTACTER LES SERVICES TECHNIQUES DE TYCO ELECTRONICS SIMEL SAS - 21220 GEVELLY CHAMBEREN FRANCE.</small>		DWN /DESSINE NIVSIS	22-Aug-08	 SIMEL PRODUCTS		
DIMENSIONS: mm		CHK /VERIFIE GODARD	22-Aug-08			
TOLERANCES UNLESS OTHERWISE SPECIFIED PER TOLERANCES NON SPECIFIEES SELON : -		APVD /APPROUVE ROYER	NAME TITRE		T 82 50 35	
		PRODUCT SPEC SPEC. PRODUIT 02BFC0031	SIZE FORMAT	CAGE CODE	DRAWING NO NO PLAN	RESTRICTED TO RESERVE A
MATERIAL MATIERE -		FINISH FINITION -	APPROX. WEIGHT MASSE APPROX. 1.9 KG	A3	00779	©-716204
		CUSTOMER DWG / PLAN CLIENT		UNIQUEMENT POUR REFERENCE	SCALE ECHELLE 1/2	SHEET FEUILLE 1 OF 1 DE 1
						REV C

ITEM: